

HPZB01/HPZB01P

ZigBee RF Transceiver Module (IEEE802.15.4)

General Description

The HopeRF HPZB01/HPZB01P RF Transceiver Module is low cost, high performance and ultra compact size Module specially designed for Ember ZigBee protocol stack for wireless networks, EmberZNet, based on IEEE 802.15.4-2003 standard in the 2.4GHz ISM band. Built-in EM357 of ember integrated a 2.4GHz IEEE 802.15.4-2003 transceiver, a 32-bit ARM® Cortex™-M3 processor, a 192KB Flash and 12KB RAM for program and data storage. It utilizes the non-intrusive SIF module for powerful software debugging and programming of the network processor. The modules eliminate the need for costly and time-consuming RF development, and shortens time to market for wireless applications with extended range requirements.

HPZB01 output power is up to +8dBm, Size is 22X15X3.2mm. HPZB01P is base on HPZB01 with additional PA , Its output power is up to +20dBm. ,Size is 26X15X3.2mm.

Three different versions of the HPZB01/HPZB01P modules are available: HPZP01-ANT/HPZB01P-ANT with built-in SMD antenna, HPZP01-IPEX/HPZB01P-IPEX with built-in IPEX connector for external antenna and HPZP01-UO/HPZB01P-UO with unbalanced RF output for external antenna.

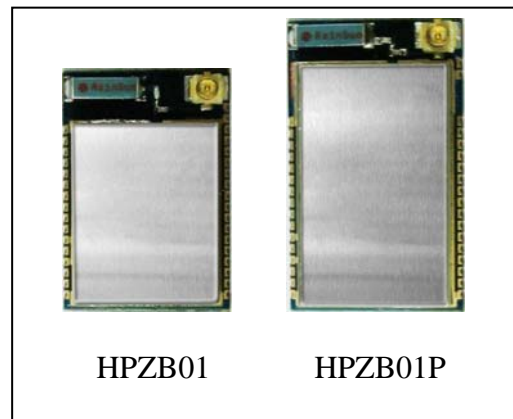

HPZB01

HPZB01P

Features

- Low cost, High performance
- Easy to use, Support all ZigBee clusters
- Can be used for coordinator, router or sleeping device
- Integrated IEEE 802.15.4-2003 PHY and MAC layer
- 32-bit ARM® Cortex™-M3 processor
- 2.4 GHz ISM band ,Up to 16 channels
- Direct sequence spread spectrum RF transceiver
- Flexible ADC, UART/SPI/TWI serial communications and general purpose timers
- Ultra compact size: 22X15X3.2mm (HPZB01)
26X15X3.2mm (HPZB01P)
- High Rx sensitivity: -102dBm (HPZB01 Boost mode)
-110dBm (HPZB01P)
- High Output power: +8dBm (HPZB01 Boost mode)
+20dBm (HPZB01P)
- Very low power consumption(<5uA in sleep mode)
- 192KB Flash and 12KB RAM
- Non-intrusive debug interface (SIF)
- AES128 encryption accelerator

Applications

The applications include, but are not limited to:

- Home automation
- lighting controls
- building control
- Inventory management
- Environmental monitoring
- Automated meter reading
- Industrial monitoring
- Security systems
- Sensor data capture

1 Pin Assignment and Pin Description

Figure 1-1:HPZB01/HPZB01P Pin Assignment

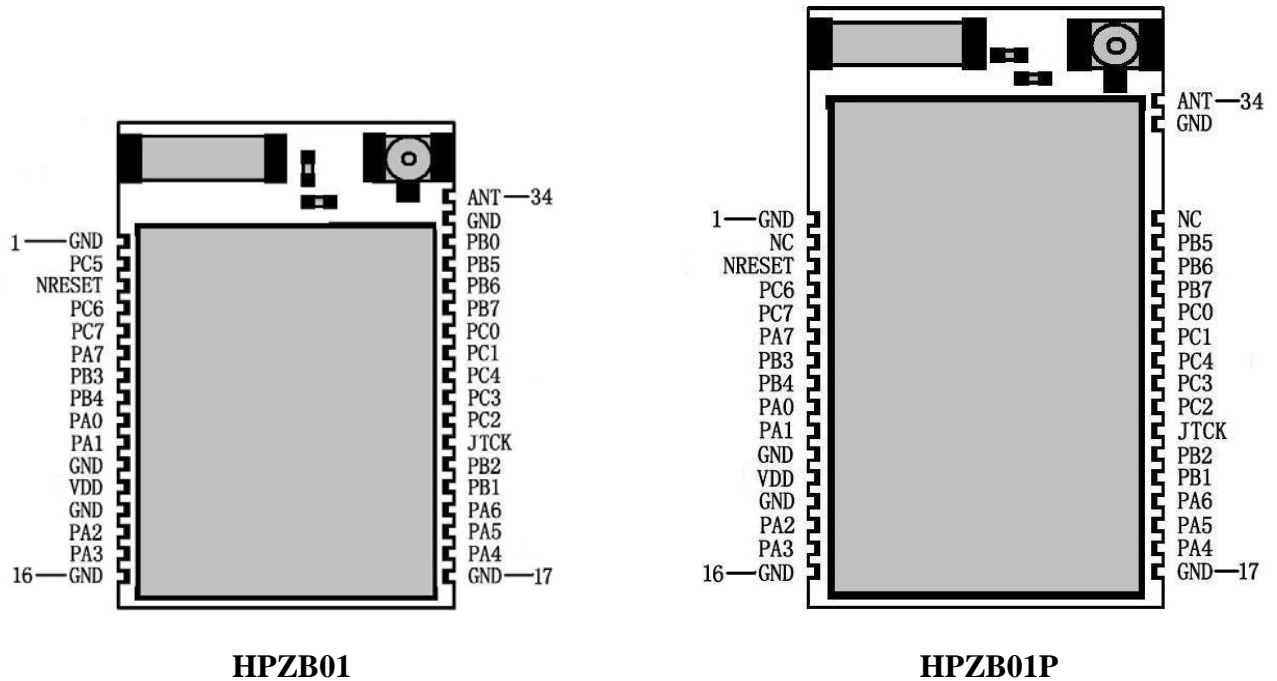

Table 1-1:HPZB01/HPZB01P Pin Description

(For more details about the Pin description, Please take the datasheet of Ember EM357 as reference)

Pin#	Signal HPZB01	Signal HPZB01P	Direction	Description
1	GND	GND	Ground	Connect to ground
2	PC5	-	I/O	Digital I/O
	TX_ACTIVE	-	O	Logic-level control for external Rx/Tx switch
3	-	NC	-	Do not connect
	nRESET	nRESET	I	Active low chip reset (internal pull-up)
4	PC6	PC6	I/O	Digital I/O
	OSC32B	OSC32B	I/O	32.768 kHz crystal oscillator
	nTX_ACTIVE	nTX_ACTIVE	O	Inverted TX_ACTIVE signal
5	PC7	PC7	I/O	Digital I/O
	OSC32A	OSC32A	I/O	32.768 kHz crystal oscillator
	OSC32_EXT	OSC32_EXT	I	Digital 32.768 kHz clock input source
6	PA7	PA7	I/O High current	Digital I/O Disable REG_EN with GPIO_DBGCFG[4]
	TIM1C4	TIM1C4	O	Timer 1 Channel 4 output
	TIM1C4	TIM1C4	I	Timer 1 Channel 4 input
	REG_EN	REG_EN	O	External regulator open drain output

Pin#	Signal HPZB01	Signal HPZB01P	Direction	Description
7	PB3	PB3	I/O	Digital I/O
	TIM2C3	TIM2C3	O	Timer 2 channel 3 output
	TIM2C3	TIM2C3	I	Timer 2 channel 3 input
	SC1nCTS	SC1nCTS	I	UART CTS handshake of Serial Controller 1
	SC1SCLK	SC1SCLK	O	SPI master clock of serial Controller 1
	SC1SCLK	SC1SCLK	I	SPI slave clock of serial Controller 1
8	PB4	PB4	I/O	Digital I/O
	TIM2C4	TIM2C4	O	Timer 2 channel 4 output
	TIM2C4	TIM2C4	I	Timer 2 channel 4 input
	SC1nRTS	SC1nRTS	O	UART RTS handshake of Serial Controller 1
	SC1nSSEL	SC1nSSEL	I	SPI slave select of serial controller 1
9	PA0	PA0	I/O	Digital I/O
	TIM2C1	TIM2C1	O	Timer 2 channel 1 output
	TIM2C1	TIM2C1	I	Timer 2 channel 1 input
	SC2MOSI	SC2MOSI	O	SPI master data out of serial controller 2
	SC2MOSI	SC2MOSI	I	SPI slave data in of serial controller 2
10	PA1	PA1	I/O	Digital I/O
	TIM2C3	TIM2C3	O	Timer 2 channel 3 output
	TIM2C3	TIM2C3	I	Timer 2 channel 3 input
	SC2SDA	SC2SDA	I/O	TWI data of serial controller 2
	SC2MISO	SC2MISO	O	SPI slave data out of serial controller 2
	SC2MISO	SC2MISO	I	SPI master data in of serial controller 2
11	GND	GND	Ground	Connect to ground
12	VDD	VDD	Power	Supply voltage (2.1V-3.6V)
13	GND	GND	Ground	Connect to ground
14	PA2	PA2	I/O	Digital I/O
	TIM2C4	TIM2C4	O	Timer 2 channel 4 output
	TIM2C4	TIM2C4	I	Timer 2 channel 4 input
	SC2SCL	SC2SCL	I/O	TWI clock of serial controller 2
	SC2SCLK	SC2SCLK	O	SPI master clock of serial controller 2
	SC2SCLK	SC2SCLK	I	SPI slave clock of serial controller 2
15	PA3	PA3	I/O	Digital I/O
	SC2nSSEL	SC2nSSEL	I	SPI slave select of serial controller 2
	TRACECLK	TRACECLK	O	Synchronous CPU trace clock
	TIM2C2	TIM2C2	O	Timer 2 channel 2 output
	TIM2C2	TIM2C2	I	Timer 2 channel 2 input
16	GND	GND	Ground	Connect to ground
17	GND	GND	Ground	Connect to ground
18	PA4	PA4	I/O	Digital I/O
	ADC4	ADC4	Analog	ADC input 4
	PTI_EN	PTI_EN	O	Frame signal of packet trace interface(PTI)
	TRACEDATA2	TRACEDATA2	O	Synchronous CPU trace data bit 2

Pin#	Signal HPZB01	Signal HPZB01P	Direction	Description
19	PA5	PA5	I/O	Digital I/O
	ADC5	ADC5	Analog	ADC input 5
	PTI_DATA	PTI_DATA	O	Data signal of packet trace interface(PTI)
	nBOOTMODE	nBOOTMODE	I	Embedded serial bootloader activation out of reset
	TRACEDATA3	TRACEDATA3	O	Synchronous CPU trace data bit 3
20	PA6	PA6	I/O High current	Digital I/O
	TIM1C3	TIM1C3	O	Timer 1 channel 3 output
	TIM1C3	TIM1C3	I	Timer 1 channel 3 input
21	PB1	PB1	I/O	Digital I/O
	SC1MISO	SC1MISO	O	SPI slave data out of serial controller 1
	SC1MOSI	SC1MOSI	O	SPI master data out of serial controller 1
	SC1SDA	SC1SDA	I/O	TWI data of serial controller 1
	SC1TXD	SC1TXD	O	UART transmit data of serial controller 1
	TIM2C1	TIM2C1	O	Timer 2 channel 1 output
	TIM2C1	TIM2C1	I	Timer 2 channel 1 input
22	PB2	PB2	I/O	Digital I/O
	SC1MISO	SC1MISO	I	SPI master data in of serial controller 1
	SC1MOSI	SC1MOSI	I	SPI slave data in of serial controller 1
	SC1SC	SC1SC	I/O	TWI clock of serial controller 1
	SC1RXD	SC1RXD	I	UART receive data of serial controller 1
	TIM2C2	TIM2C2	O	Timer 2 channel 2 output
	TIM2C2	TIM2C2	I	Timer 2 channel 2 input
23	JTCK	JTCK	I	JTAG clock input from debugger
	SWCLK	SWCLK	I/O	Serial Wire Clock input/output with debugger
24	PC2	PC2	I/O	Digital I/O
	JTDO	JTDO	O	JTAG data out to debugger
	SWO	SWO	O	Serial Wire Output asynchronous trace output to debugger
25	PC3	PC3	I/O	Digital I/O
	JTDI	JTDI	I	JTAG data in from debugger
26	PC4	PC4	I/O	Digital I/O
	JTMS	JTMS	I	JTAG mode select from debugger
	SWDIO	SWDIO	I/O	Serial Wire bidirectional data to/from debugger
27	PC1	PC1	I/O	Digital I/O
	ADC3	ADC3	Analog	ADC input 3
	SWO	SWO	O	Serial Wire Output asynchronous trace output to debugger
	TRACEDATA0	TRACEDATA0	O	Synchronous CPU trace data bit 0
28	PC0	PC0	I/O High current	Digital I/O
	JRST	JRST	I	JTAG reset input from debugger
	IRQD ¹	IRQD ¹	I	Default external interrupt source D
	TRACEDATA1	TRACEDATA1	O	Synchronous CPU trace data bit 1

Pin#	Signal HPZB01	Signal HPZB01P	Direction	Description
29	PB7	PB7	I/O High current	Digital I/O
	ADC2	ADC2	Analog	ADC Input 2
	IRQC ¹	IRQC ¹	I	Default external interrupt source C
	TIM1C2	TIM1C2	O	Timer 1 channel 2 output
	TIM1C2	TIM1C2	I	Timer 1 channel 2 input
30	PB6	PB6	I/O High current	Digital I/O
	ADC1	ADC1	Analog	ADC Input 1
	IRQB	IRQB	I	External interrupt source B
	TIM1C1	TIM1C1	O	Timer 1 channel 1 output
	TIM1C1	TIM1C1	I	Timer 1 channel 1 input
31	PB5	PB5	I/O	Digital I/O
	ADC0	ADC0	Analog	ADC Input 0
	TIM2CLK	TIM2CLK	I	Timer 2 external clock input
	TIM1MSK	TIM1MSK	I	Timer 1 external clock mask input
32	PB0	-	I/O	Digital I/O
	VREF	-	Analog O	ADC reference output
	VREF	-	Analog I	ADC reference input
	IRQA	-	I	External interrupt source A
	TRACECLK	-	O	Synchronous CPU trace clock
	TIM1CLK	-	I	Timer 1 external clock input
	TIM2MSK	-	I	Timer 2 external clock mask input
	-	NC	-	Do not connect
33	GND	GND	Ground	Connect to ground
34	ANT	ANT	I/O	Unbalanced RF input/output , Connect to external antenna for HPZB01-UO and HPZB01P-UO

2 Electrical Characteristics

2.1 Absolute Maximum Ratings

Table 2-1: Absolute Maximum Ratings

Parameter	Test Conditions	Min.	Max.	Unit
Regulator input voltage (VDD)		-0.3	+3.6	V
RF Input Power (for max level for correct packet reception)			+15	dBm
Voltage on any GPIO pin (PA4, PA5, PB5, PB6, PB7, PC1), when used as an input to the general purpose ADC with the low voltage range selected		-0.3	2.0	V
Voltage on any GPIO (PA[7:0], PB[7:0], PC[7:0]), SWCLK, nRESET, VREG_OUT		-0.3	VDD +0.3	V
Voltage on OSCA, OSCB, NC		-0.3	1.9V +0.3	V
Storage temperature		-40	+140	°C

2.2 Recommended Operating Conditions

Table 2-2: Operating Conditions

Parameter	Test Conditions	Min.	Typ.	Max.	Unit
Regulator input voltage (VDD)		2.1		3.6	V
Operating temperature range(note1)		-20		+70	°C

note1: -40°C to +85°C operational

2.3 Electrical Specifications

Table 2-3: Electrical Specifications

(VCC = 3.0V, Fo =2440MHZ, T=25°C, if nothing else stated)

Parameter	Test Conditions	Min.	Typ.	Max.	Unit
Operating frequency		2400		2500	MHZ
Supply voltage		2.1		3.6	V
Numbers of channels	For IEEE 802.15.4 compliance		16		
Channel spacing	For IEEE 802.15.4 compliance		5		MHz
Maximum output power	HPZB01 Programmable	-55		+8	dBm
	HPZB01P with PA		+20		dBm

Parameter	Test Conditions	Min.	Typ.	Max.	Unit
Sensitivity	HPZB01 PER = 1% PER, 20byte packet defined by IEEE 802.15.4 Boost mode		-102		dBm
	HPZB01 PER = 1% PER, 20byte packet defined by IEEE 802.15.4		-100		dBm
	HPZB01P with LNA PER = 1% PER, 20byte packet defined by IEEE 802.15.4		-110		dBm
Tx Current	HPZB01 +8dBm transmission power		42		mA
	HPZB01 +3dBm transmission power		29		mA
	HPZB01P with PA +20dBm transmission power		170		mA
Rx Current	HPZB01 boost mode		29		mA
	HPZB01 normal mode		27		mA
	HPZB01P with LNA		38		mA
On-Air Data Rate			250		Kbps
Deep sleep current			5		uA
Frequency stability				+/-40	ppm
RF Input/output impedance	IPEX connector output Unbalanced output		50		Ohm
Flash Memory Size			192		KB
RAM Size			12		KB
Main system clock frequency			24		MHz
Sub system clock frequency			32.768		KHz

3 Block Diagram

Figure 3-1: HPZB01-ANT Block Diagram

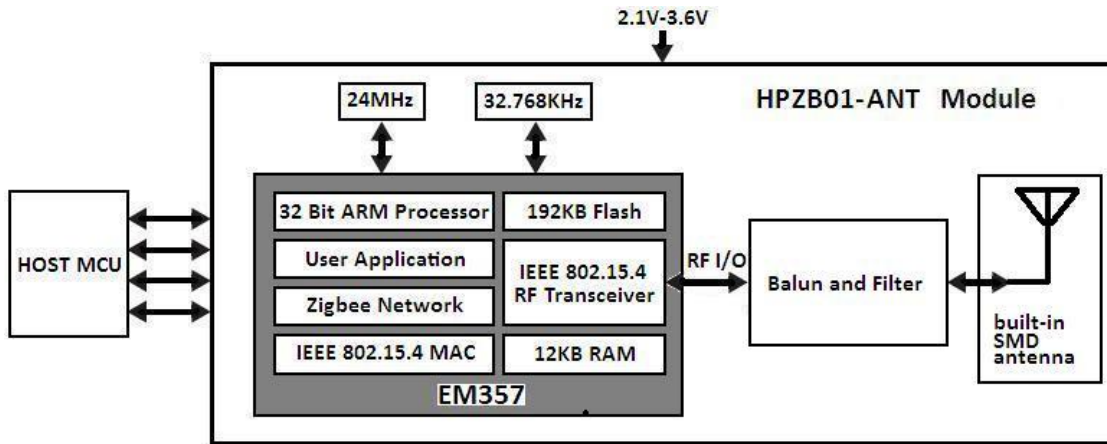

Figure 3-2: HPZB01-IPEX Block Diagram

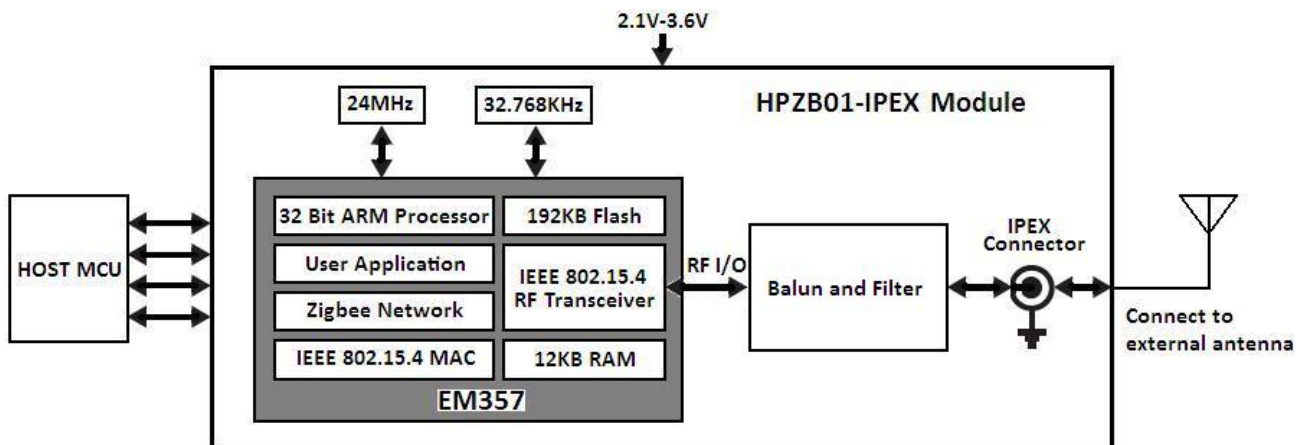

Figure 3-3: HPZB01-UO Block Diagram

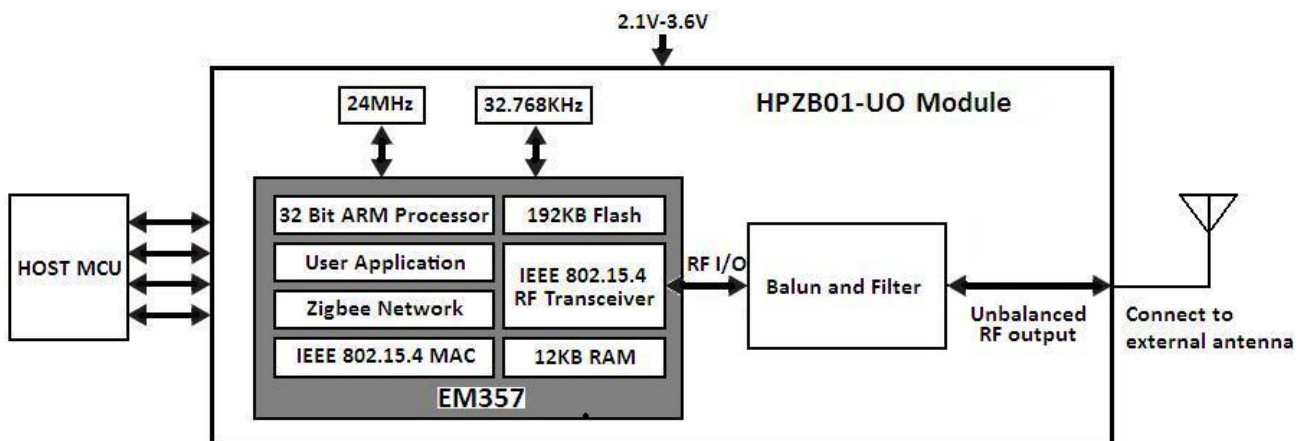

Figure 3-4: HPZB01P-ANT Block Diagram

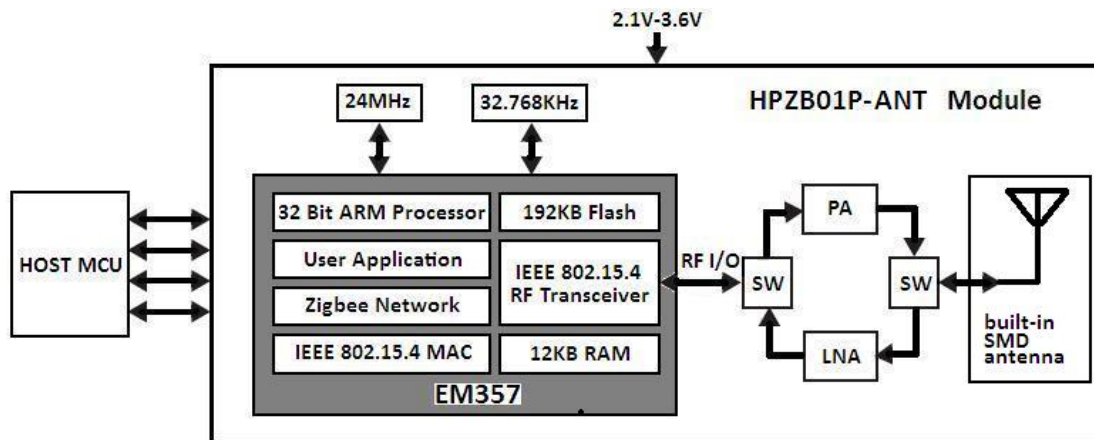

Figure 3-5: HPZB01P-IPEX Block Diagram

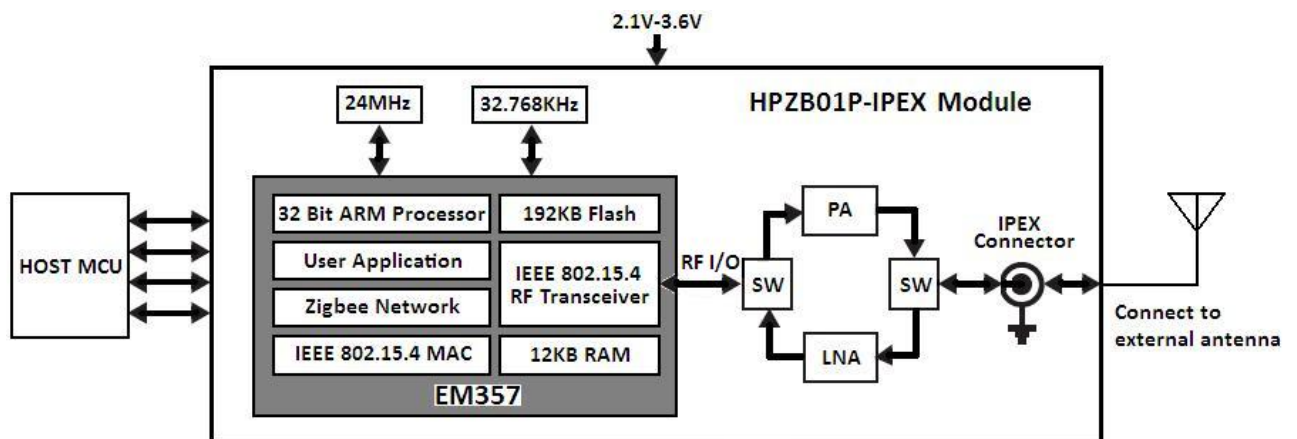
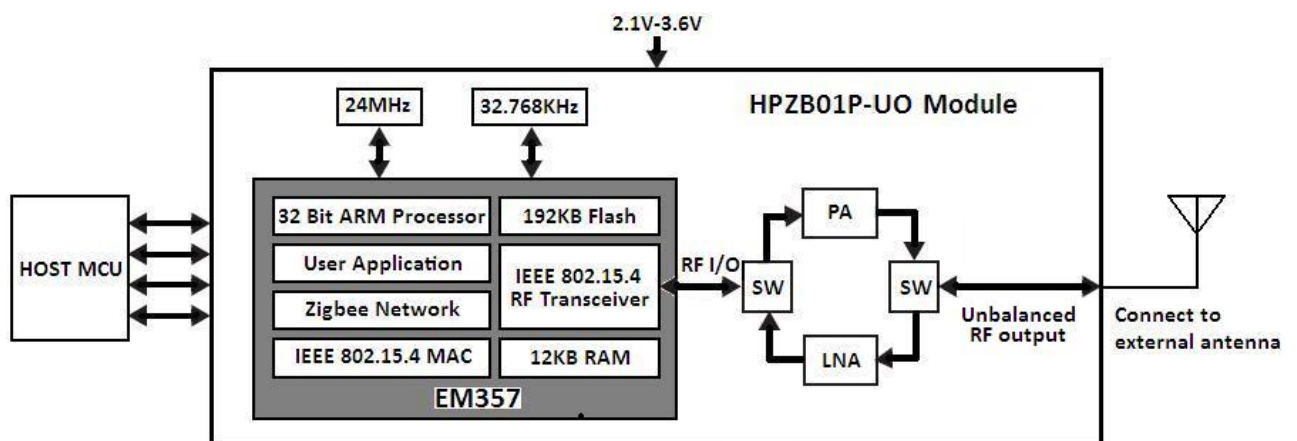

Figure 3-6: HPZB01P-UO Block Diagram



4 PCB Layout Recommendations

As the HPZB01(P)-ANT module integrated with SMD antenna, The mounting position of the module will have great impact on the RF performance. There should not be any trace, ground plane , metal part and PCB underneath or nearby the area of the SMD antenna. Except the area of the SMD antenna, A ground plane under the module is preferred. The figure below shows an example how the module positioned on the mother PCB.

Figure 4-1: A recommended placement of the module on a main PCB

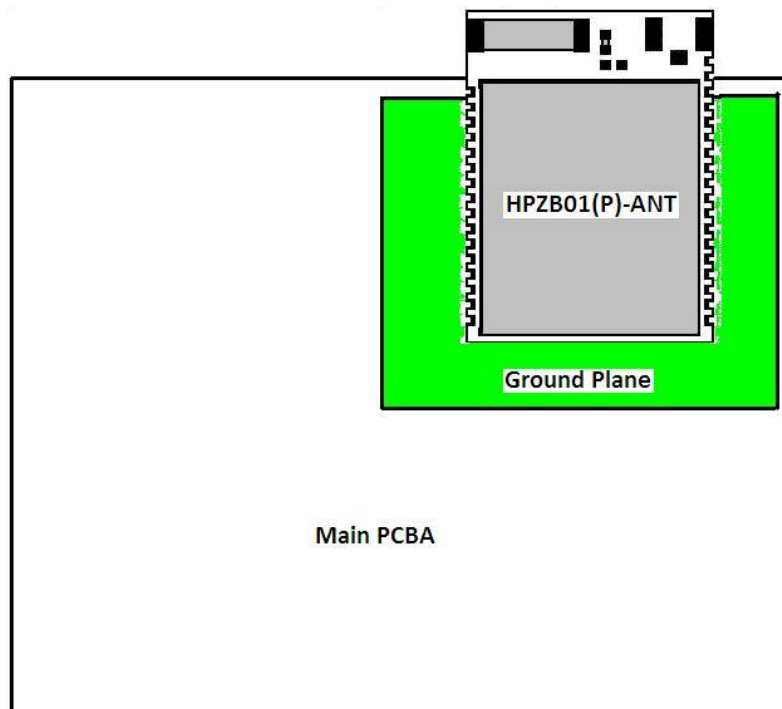

Use ferrite bead and 1uF capacitor located closely to the power supply pin is recommended, As shown below.

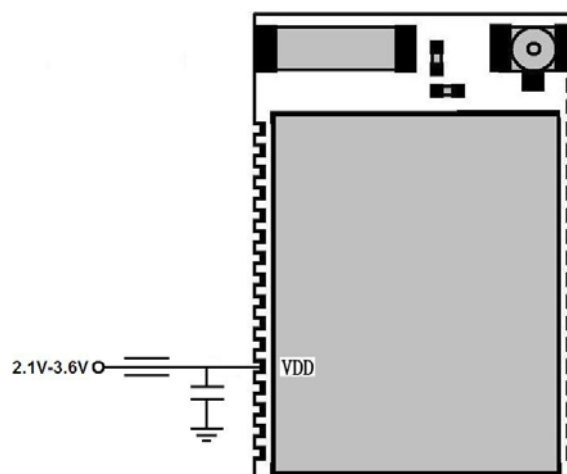

5 Mechanical Dimensions

All dimensions in MM

Figure 5-1: HPZB01 Mechanical Dimensions

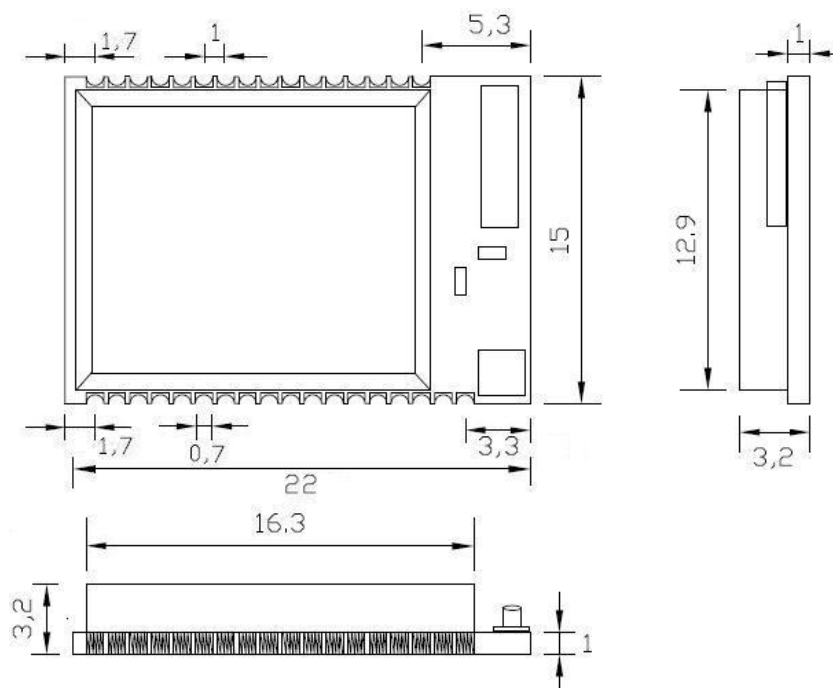
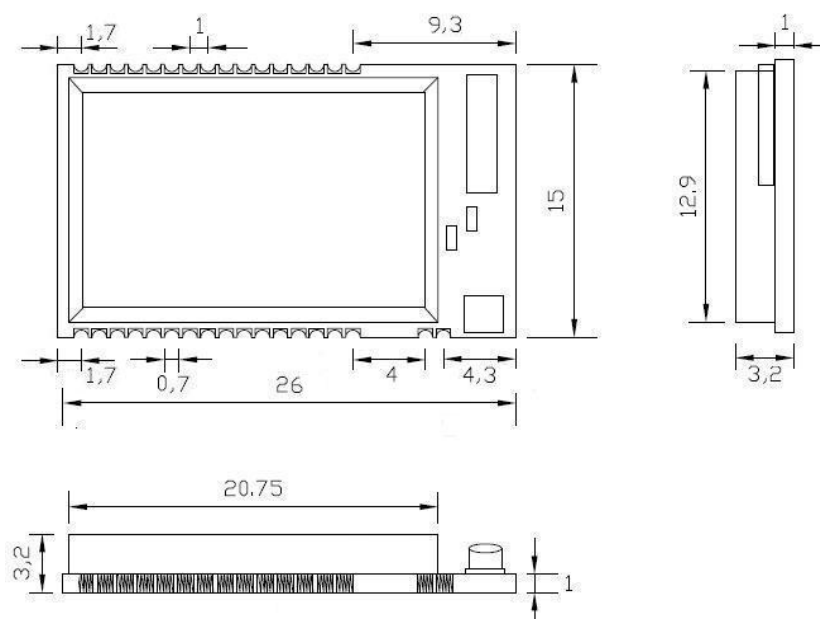

Figure 5-2: HPZB01P Mechanical Dimensions



6 Mounting Information

The below diagrams show the PCB footprint recommended for the modules.
All dimensions in MM

Figure6-1: HPZB01(P)-ANT and HPZB01(P)-IPEX module Recommended PCB footprint ,Top View

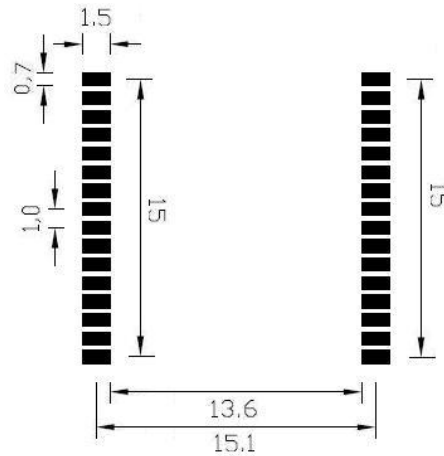

Figure6-2: HPZB01-UO module Recommended PCB footprint, Top View

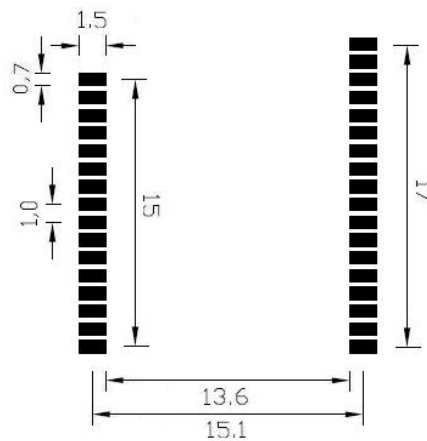
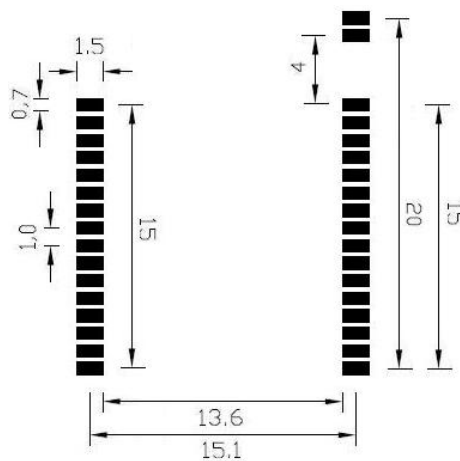

Figure6-3: HPZB01P-UO module Recommended PCB footprint, Top View



7 Soldering Profile

Table7-1: Soldering Profile

Profile Feature	Green Package
Average ramp-up rate(217°C to peak)	3°C/s max
Preheat temperature 175°C +/-25°C	180s max
Temperature maintained above 217°C	60S to 150S
Time within 5°C of actual peak temperature	20s to 40s
Peak temperature rang	260°C
Ramp-down rate	6°C/s max
Time within 25°C to peak temperature	8 minutes max

8 Ordering Information

Table8-1: Ordering Information

Part Number	Description
HPZB01-ANT	+8dBm output power, -102dBm sensitivity, With built-in SMD antenna
HPZB01P-ANT	+20dBm output power, -110dBm sensitivity, With built-in SMD antenna
HPZB01-IPEX	+8dBm output power, -102dBm sensitivity, With Built-in IPEX connector for external antenna
HPZB01P-IPEX	+20dBm output power, -110dBm sensitivity, With Built-in IPEX connector for external antenna
HPZB01-UO	+8dBm output power, -102dBm sensitivity, With unbalanced RF output for external antenna
HPZB01P-UO	+20dBm output power, -110dBm sensitivity, With unbalanced RF output for external antenna

HOPE MICROELECTRONICS CO.,LTD

Add:4/F, Block B3, East Industrial Area, Huaqiaocheng,
Shenzhen, Guangdong, China

Tel: 86-755-82973805

Fax: 86-755-82973550

Email: sales@hoperf.com
trade@hoperf.com

Website: <http://www.hoperf.com>
<http://hoperf.en.alibaba.com>

This document may contain preliminary information and is subject to change by Hope Microelectronics without notice. Hope Microelectronics assumes no responsibility or liability for any use of the information contained herein. Nothing in this document shall operate as an express or implied license or indemnity under the intellectual property rights of Hope Microelectronics or third parties. The products described in this document are not intended for use in implantation or other direct life support applications where malfunction may result in the direct physical harm or injury to persons. NO WARRANTIES OF ANY KIND, INCLUDING, BUT NOT LIMITED TO, THE IMPLIED WARRANTIES OF MERCHANTABILITY OR FITNESS FOR A PARTICULAR PURPOSE, ARE OFFERED IN THIS DOCUMENT.

©2006, HOPE MICROELECTRONICS CO.,LTD. All rights reserved.