

USBMOD232R - USB to Parallel FIFO Development Module

The USBMOD232R shown in Diagram 1, is the latest RoHS compliant, low-cost integrated module for transferring serial data over USB. The module is based on the FT232R USB to Serial UART IC from FTDI. The USBMOD232R is capable of transfer rates of up to 1000k baud (RS232) and 3000k baud (RS422 / RS485).

The USBMOD232R offers a complete plug and play solution for implementing the FT232R into both new and existing designs, which makes the module ideal for rapid prototyping and development.

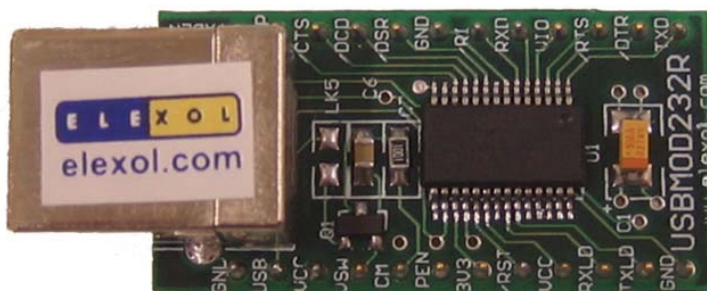

Diagram 1

MODULE FEATURES

- Single module High-Speed USB Serial UART solution that is based on the FTDI FT232R USB IC
- Integrated Type-B USB Connector
- RoHS Compliant
- No external passive components required
- Module can be configured for both External and Bus powered operation.
- On board power switching circuit for high bus powered applications
- 24-pin Dual In-Line Package (Ideal for prototyping)

FT232R FEATURES

- Single chip USB to asynchronous serial data transfer interface.
- Entire USB protocol handled on the chip - No USB-specific firmware programming required.
- UART interface support for 7 or 8 data bits, 1 or 2 stop bits and odd / even / mark / space / no parity.
- Fully assisted hardware or X-On / X-Off software handshaking.
- Data transfer rates from 300 baud to 3 Megabaud (RS422 / RS485 and at TTL levels) and 300 baud to 1 Megabaud (RS232).
- 256 byte receive buffer and 128 byte transmit buffer utilising buffer smoothing technology to allow for high data throughput.
- FTDI's royalty-free VCP and D2XX drivers eliminate the requirement for USB driver development in most cases.
- In-built support for event characters and line break condition.
- New USB FTDI Chip-ID™ feature.
- New configurable CBUS I/O pins.
- Auto transmit buffer control for RS485 applications.
- Transmit and receive LED drive signals.
- New 48MHz, 24MHz, 12MHz, and 6MHz clock output signal Options for driving external MCU or FPGA.
- FIFO receive and transmit buffers for high data throughput.
- Adjustable receive buffer timeout.
- Synchronous and asynchronous bit bang mode interface options with RD# and WR# strobes.
- New CBUS bit bang mode option.
- Integrated 1024 Bit internal EEPROM for storing USB VID, PID, serial number and product description strings, and CBUS I/O configuration.
- Device supplied preprogrammed with unique USB serial number.
- Support for USB suspend and resume.
- Support for bus powered, self powered, and high-power bus powered USB configurations.
- Integrated 3.3V level converter for USB I/O .
- Integrated level converter on UART and CBUS for interfacing to 5V - 1.8V Logic.
- True 5V / 3.3V / 2.8V / 1.8V CMOS drive output and TTL input.
- High I/O pin output drive option.
- Integrated USB resistors.
- Integrated power-on-reset circuit.
- Fully integrated clock - no external crystal, oscillator, or resonator required.
- Fully integrated AVCC supply filtering - No separate AVCC pin and no external R-C filter required.
- UART signal inversion option.
- USB bulk transfer mode.
- 3.3V to 5.25V Single Supply Operation.
- Low operating and USB suspend current.
- Low USB bandwidth consumption.
- UHCI / OHCI / EHCI host controller compatible
- USB 2.0 Full Speed compatible.
- -40°C to 85°C extended operating temperature range.
- Available in compact Pb-free 28 Pin SSOP and QFN-32 packages (both RoHS compliant).

FT232R ENHANCEMENTS

This section summarises the enhancements and the key features of the FT232R device. For further details, on the FT232R consult the FT232R datasheet which is available for download from the FTDI website. (<http://www.ftdichip.com>)

Integrated Clock Circuit - Previous generations of FTDI's USB UART devices required an external crystal or ceramic resonator. The clock circuit has now been integrated onto the device meaning that no crystal or ceramic resonator is required. However, if required, an external 12MHz crystal can be used as the clock source.

Integrated EEPROM - Previous generations of FTDI's USB UART devices required an external EEPROM if the device were to use USB Vendor ID (VID), Product ID (PID), serial number and product description strings other than the default values in the device itself. This external EEPROM has now been integrated onto the FT232R chip meaning that all designs have the option to change the product description strings.

A user area of the internal EEPROM is available for storing additional data. The internal EEPROM is programmable in circuit, over USB without any additional voltage requirement.

Preprogrammed EEPROM - The FT232R is supplied with its internal EEPROM preprogrammed with a serial number that is unique to each individual device. This, in most cases, will remove the need to program the device EEPROM.

Integrated USB Resistors - Previous generations of FTDI's USB UART devices required two external series resistors on the USBDP and USBDM lines, and a 1.5 kΩ pull up resistor on USBDP. These three resistors have now been integrated onto the device.

Integrated AVCC Filtering - Previous generations of FTDI's USB UART devices had a separate AVCC pin - the supply to the internal PLL. This pin required an external R-C filter. The separate AVCC pin is now connected internally to VCC, and the filter integrated onto the chip.

Less External Components - Integration of the crystal, EEPROM, USB resistors, and AVCC filter will substantially reduce the bill of materials cost for USB interface designs using the FT232R compared to its FT232BM predecessor.

Transmit and Receive Buffer Smoothing - The FT232R's 256 byte receive buffer and 128 byte transmit buffer utilise new buffer smoothing technology to allow for high data throughput.

Configurable CBUS I/O Pin Options - There are now 5 configurable Control Bus (CBUS) lines. Options are **TXDEN** - transmit enable for RS485 designs, **PWREN#** - Power control for high power, bus powered designs, **TXLED#** - for pulsing an LED upon transmission of data, **RXLED#** - for pulsing an LED upon receiving data, **TX&RXLED#** - which will pulse an LED upon transmission OR reception of data, **SLEEP#** - indicates that the device going into USB suspend mode, **CLK48 / CLK24 / CLK12 / CLK6** - 48MHz, 24MHz, 12MHz, and 6MHz clock output signal options. There is also the option to bring out bit bang mode read and write strobes (see below). The CBUS lines can be configured with any one of these output options by setting bits in the internal EEPROM. The device is supplied with the most commonly used pin definitions preprogrammed - see [Section 10](#) for details.

Enhanced Asynchronous Bit Bang Mode with RD# and WR# Strobes - The FT232R supports FTDI's BM chip bit bang mode. In bit bang mode, the eight UART lines can be switched from the regular interface mode to an 8-bit general purpose I/O port. Data packets can be sent to the device and they will be sequentially sent to the interface at a rate controlled by an internal timer (equivalent to the baud rate prescaler). With the FT232R device this mode has been enhanced so that the internal RD# and WR# strobes are now brought out of the device which can be used to allow external logic to be clocked by accesses to the bit bang I/O bus. This option will be described more fully in a separate application note.

Synchronous Bit Bang Mode - Synchronous bit bang mode differs from asynchronous bit bang mode in that the interface pins are only read when the device is written to. Thus making it easier for the controlling program to measure the response to an output stimulus as the data returned is synchronous to the output data. The feature was previously seen in FTDI's FT2232C device. This option will be described more fully in a separate application note.

CBUS Bit Bang Mode - This mode allows four of the CBUS pins to be individually configured as GPIO pins, similar to Asynchronous bit bang mode. It is possible to use this mode while the UART interface is being used, thus providing up to four general purpose I/O pins which are available during normal operation. An application note describing this feature is available separately from the [FTDI website](#).

Lower Supply Voltage - Previous generations of the chip required 5V supply on the VCC pin. The FT232R will work with a VCC supply in the range 3.3V - 5.25V. Bus powered designs would still take their supply from the 5V on the USB bus, but for self powered designs where only 3.3V is available and there is no 5V supply there is no longer any need for an additional external regulator.

Integrated Level Converter on UART Interface and Control Signals - VCCIO pin supply can be from 1.8V to 5V. Connecting the VCCIO pin to 1.8V, 2.8V, or 3.3V allows the device to directly interface to 1.8V, 2.8V or 3.3V and other logic families without the need for external level converter I.C. devices.

5V / 3.3V / 2.8V / 1.8V Logic Interface - The FT232R provides *true* CMOS Drive Outputs and TTL level Inputs.

Integrated Power-On-Reset (POR) Circuit - The device incorporates an internal POR

function. A RESET# pin is available in order to allow external logic to reset the FT232R where required. However, for many applications the RESET# pin can be left unconnected, or pulled up to VCCIO.

Lower Operating and Suspend Current - The device operating supply current has been further reduced to 15mA, and the suspend current has been reduced to around 70µA. This allows greater margin for peripheral designs to meet the USB suspend current limit of 500µA.

Low USB Bandwidth Consumption - The operation of the USB interface to the FT232R has been designed to use as little as possible of the total USB bandwidth available from the USB host controller.

High Output Drive Option - The UART interface and CBUS I/O pins can be made to drive out at three times the standard signal drive level thus allowing multiple devices to be driven, or devices that require a greater signal drive strength to be interfaced to the FT232R. This option is enabled in the internal EEPROM.

Power Management Control for USB Bus Powered, High Current Designs- The PWREN# signal can be used to directly drive a transistor or P-Channel MOSFET in applications where power switching of external circuitry is required. An option in the internal EEPROM makes the device gently pull down on its UART interface lines when the power is shut off (PWREN# is high). In this mode any residual voltage on external circuitry is bled to GND when power is removed, thus ensuring that external circuitry controlled by PWREN# resets reliably when power is restored.

UART Pin Signal Inversion - The sense of each of the eight UART signals can be individually inverted by setting options in the internal EEPROM. Thus, CTS# (active low) can be changed to CTS (active high), or TXD can be changed to TXD#.

FTDChip-ID™ - Each FT232R is assigned a unique number which is burnt into the device at manufacture. This ID number cannot be reprogrammed by product manufacturers or end-users. This allows the possibility of using FT232R based dongles for software licensing. Further to this, a renewable license scheme can be implemented based on the FTDChip-ID™ number when encrypted with other information. This encrypted number can be stored in the user area of the FT232R internal EEPROM, and can be decrypted, then compared with the protected FTDChip-ID™ to verify that a license is valid. Web based applications can be used to maintain product licensing this way. An application note describing this feature is available separately from the [FTDI website](#).

Improved EMI Performance - The reduced operating current and improved on-chip VCC decoupling significantly improves the ease of PCB design requirements in order to meet FCC, CE and other EMI related specifications.

Programmable Receive Buffer Timeout - The receive buffer timeout is used to flush remaining data from the receive buffer. This time defaults to 16ms, but is programmable over USB in 1ms increments from 1ms to 255ms, thus allowing the device to be optimised for protocols that require fast response times from short data packets.

Extended Operating Temperature Range - The FT232R operates over an extended temperature range of -40° to +85° C thus allowing the device to be used in automotive and industrial applications.

New Package Options - The FT232R is available in two packages - a compact 28 pin SSOP (**FT232RL**) and an ultra-compact 5mm x 5mm pinless QFN-32 package (**FT232RQ**). Both packages are lead (Pb) free, and use a 'green' compound. Both packages are fully compliant with European Union directive 2002/95/EC.

MODULE PINOUT & PIN DESCRIPTIONS

As mentioned above in module features, the USBMOD232R is in a 24-pin Dual In-Line Package. This allows the module to fit into a standard 24-pin 600mil IC Socket, which makes the module ideal for prototyping and development work.

Shown in Diagram 2 below is the pin out for the USBMOD232R.

USBMOD232R PINOUT

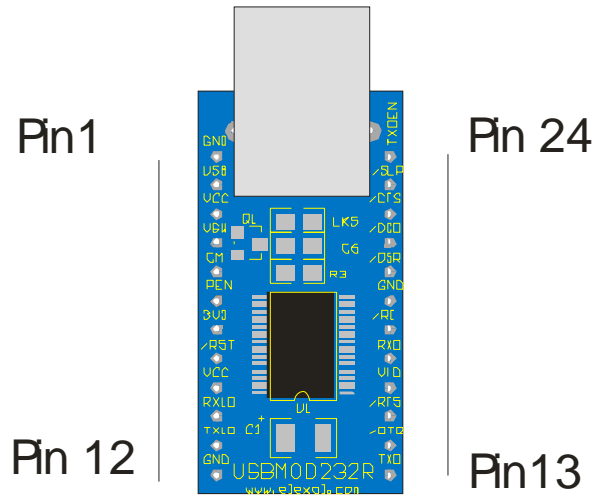

DIAGRAM 2

On the following page is the pin out table detailing the various pin functions of the module.

USBMOD232R PINOUT TABLE

PIN #	SIGNAL	TYPE	DESCRIPTION
1	GND	PWR	Device – Ground Supply Pin
2	USB	PWR	USB Bus Power
3	VCC	PWR	Device - +4.4 volt to +5.25 volt Power Supply Pin NOTE: No external voltage is required when Bus Powered
4	VSW	PWR	Switched Power supply pin for external devices. Is controlled via the CM pin which is connected to PEN, in bus powered mode with power switching. NOTE: No external voltage is required when Bus Powered
5	CM	IN	Connect to PEN to control the external power switching of external devices in USB bus powered operation
6	PEN	OUT	Goes Low after the device is configured via USB, then high during USB suspend. Can be connected to CM, to control power to external logic powered from VSW. Enable the Interface Pull-Down Option in EEPROM when using the /PEN pin in this way.
7	3V3	OUT	3.3 volt Output from the integrated L.D.O. regulator. Up to 50mA of current can be drawn from this pin to power external 3.3v logic if required.
8	/RST	IN	Can be used by external device to reset FT232R.
9	VCC	PWR	Device - +4.4 volt to +5.25 volt Power Supply Pin NOTE: No external voltage is required when Bus Powered
10	RXLD	OUT	Receive data LED Drive – pulses low when transmitting data via USB
11	TXLD	OUT	Transmit data LED Drive – pulses low when transmitting data via USB
12	GND	PWR	Device – Ground Supply Pin
13	TXD	OUT	Transmit Asynchronous Data Output
14	/DTR	OUT	Data Terminal Ready Control Output / Handshake Signal
15	/RTS	OUT	Request to Send Control Output / Handshake Signal
16	VIO	PWR	+1.8V volt to +5.25 volt VCC to the FIFO interface pins. Placing LK4 (remove LK3) will power the FIFO pins to 3V3, otherwise place LK3 to drive out at 5v CMOS level. If driving other voltages via VIO be sure to remove both LK3 & LK4
17	RXD	IN	Receive Asynchronous Data Input
18	RI	IN	Ring Indicator Control Input. When remote wake up is enabled in the internal EEPROM taking RI low can be used to resume the PC USB host controller from suspend
19	GND	PWR	Device – Ground Supply Pin
20	/DSR	IN	Data Set Ready Control Input/ Handshake Signal
21	/DCD	IN	Data Carrier Detect Control Input
22	/CTS	IN	Clear To Send Control input / Handshake Signal
23	SLP	OUT	Goes Low during USB Suspend mode. Can be used to power down external TTL to RS232 converters.
24	TXDEN	OUT	Enable transmit data for RS485

MODULE CONFIGURATIONS

BUS POWERED OPERATION

The USBMOD232R is configured to be bus powered off the assembly line. There are no external pins that are required to be connected in order for the device to enumerate.

BUS POWERED OPERATION with Power switching

The USBMOD232R can be easily configured for bus powered operation with power switching.

1. Place LK5 with 0R0
2. Set the Pull-down on suspend option in the internal EEPROM
3. Connect the PEN pin to CM pin
4. Make sure that the external logic that is being switched has its own reset circuitry so that it will automatically reset when coming out of suspend mode.

SELF POWERED OPERATION

To self power the USBMOD232R the process is as follows:

1. Remove LK1 keep the 0R0 and move it LK2.
2. Place LK2 with the 0R0 taken from LK1.
3. Place R1 (4k7 0805) and R2 (10K 0805)
4. Connect VCC to an external 5V supply.

SCHEMATIC

The following page shows the schematic for the USBMOD232R.

USBMOD232R SCHEMATIC

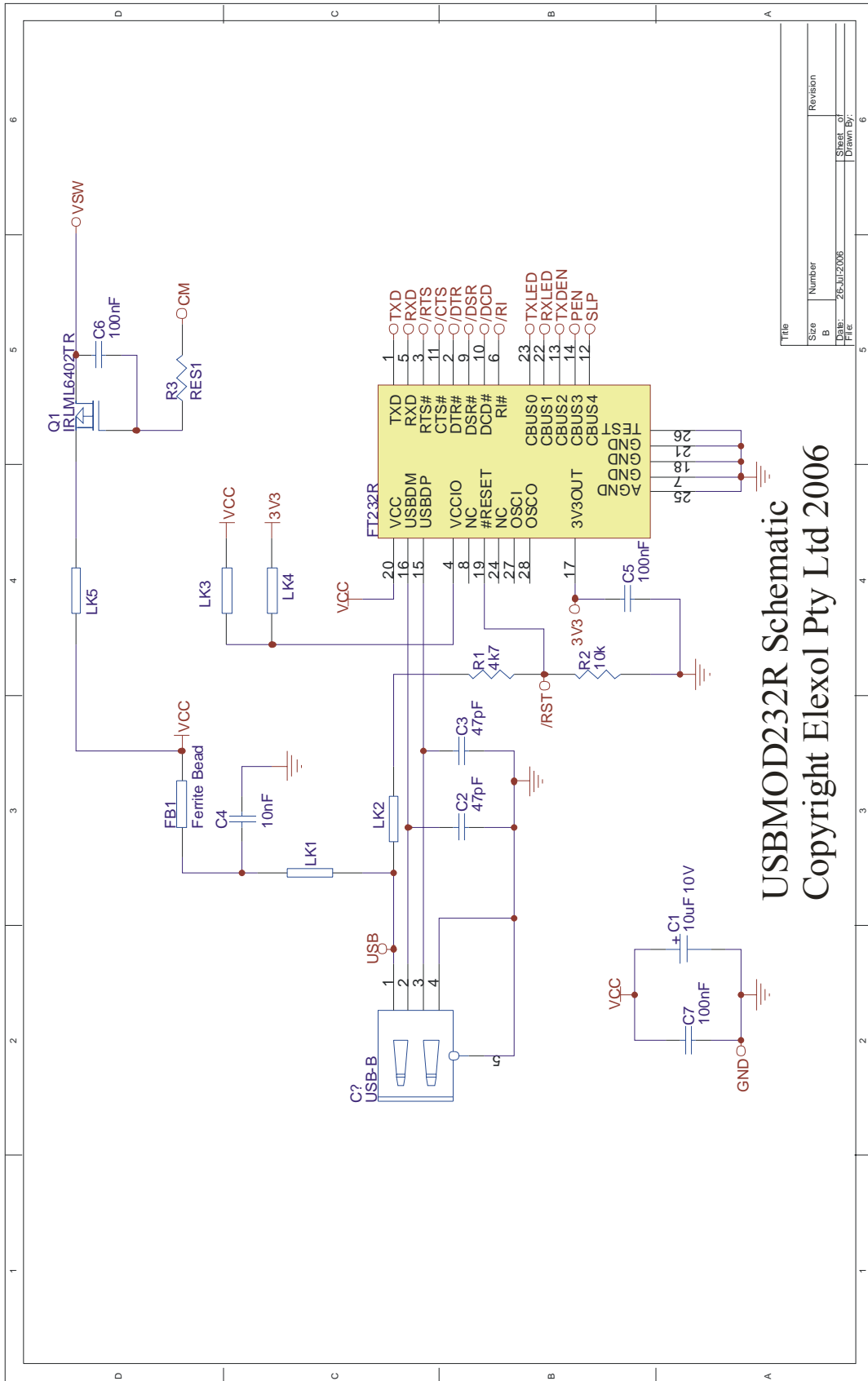

USBMOD232R Schematic
Copyright Elexol Pty Ltd 2006

MECHANICALS

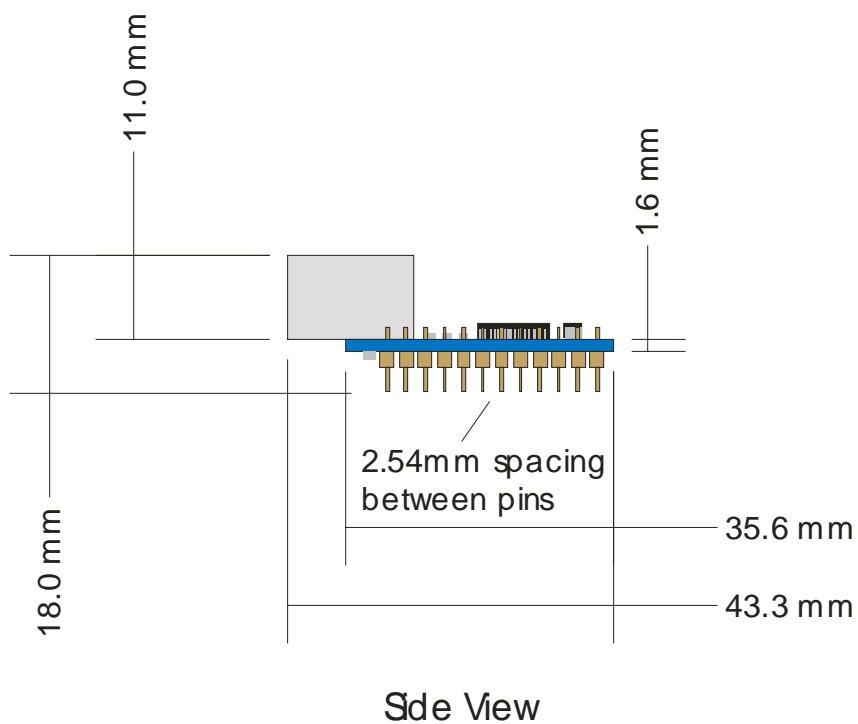
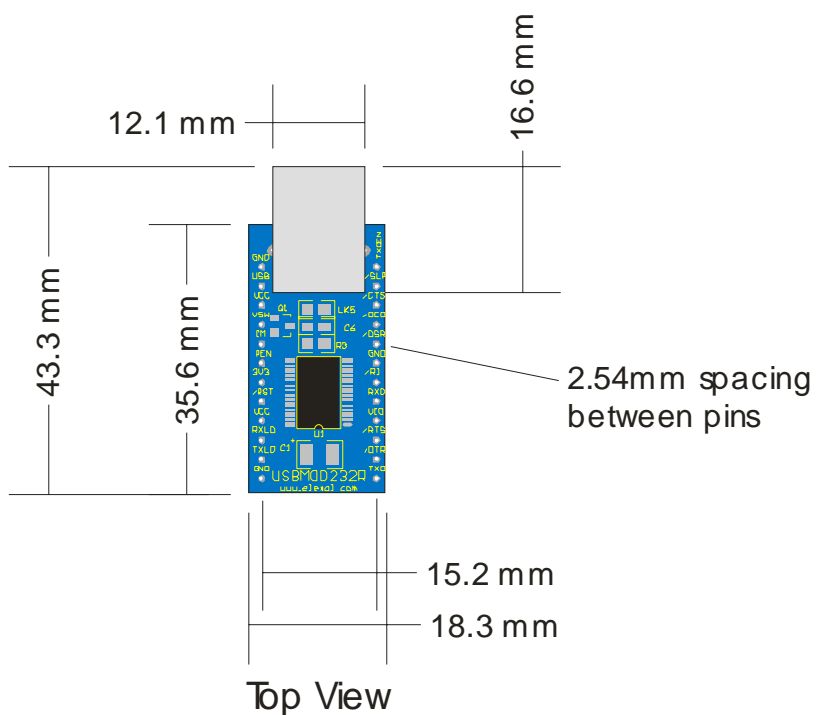

All dimensions are shown in millimeters.

The USBMOD232R uses all lead free components.

SOFTWARE DRIVERS

There are drivers available for the different operating systems which are listed below. These drivers are available to download for free from the FTDI website. <http://www.ftdichip.com>

Royalty-Free VIRTUAL COM PORT (VCP) DRIVERS for...

- Windows 98, 98SE, ME, 2000, Server 2003, XP.
- Windows Vista / Longhorn*
- Windows XP 64-bit.*
- Windows XP Embedded.
- Windows CE.NET 4.2 & 5.0
- MAC OS 8 / 9, OS-X
- Linux 2.4 and greater

Royalty-Free D2XX *Direct* Drivers (USB Drivers + DLL S/W Interface)

- Windows 98, 98SE, ME, 2000, Server 2003, XP.
- Windows Vista / Longhorn*
- Windows XP 64-bit.*
- Windows XP Embedded.
- Windows CE.NET 4.2 & 5.0
- Linux 2.4 and greater

* Currently Under Development. Contact FTDI for availability.

D2XX Programmers guide is also available for download from the FTDI website.

ABSOLUTE MAXIMUM RATINGS

Storage Temperature	-65°C to + 150°C
Ambient Temperature (Power Applied).....	-40°C to + 85°C
VCC Supply Voltage	-0.5V to +6.00V
DC Input Voltage – USBDP and USBDM.....	-0.5V to 3.8V
DC Input Voltage - High Impedance Bidirectionals	-0.5V to VCC + 0.5V
DC Input Voltage – All Other Inputs	-0.5V to VCC + 0.5V
DC Output Current – Outputs	24mA
DC Output Current – Low Impedance Bidirectionals	24mA
Power Dissipation (VCC = 5.25V).....	500mW

DC CHARACTERISTICS

(Ambient Temperature = -40°C to 85°C)

Operating Voltage and Current

<i>Parameter</i>	<i>Description</i>	<i>Min</i>	<i>Typ</i>	<i>Max</i>	<i>Units</i>	<i>Conditions</i>
Vcc1	VCC Operating Supply Voltage	3.3	-	5.25	V	
Vcc2	VIO Operating Supply Voltage	1.8	-	5.25	V	
Icc1	Operating Supply Current	-	15	-	mA	Normal Operation
Icc2	Operating Supply Current	50	70	100	uA	USB Suspend

UART / Control Bus I/O Pin Characteristics (VIO = 5V)

<i>Parameter</i>	<i>Description</i>	<i>Min</i>	<i>Typ</i>	<i>Max</i>	<i>Units</i>	<i>Conditions</i>
Voh	Output Voltage High	3.2	4.1	4.9	V	I source = 2 mA
Vol	Output Voltage Low	0.3	0.4	0.6	V	I sink = 2 mA
Vin	Input Switching Threshold	1.3	1.6	1.9	V	* Note 1
VHys	Input Switching Hysteresis	50	55	60	mV	* Note 1

* Note 1 – Inputs have an internal 200kΩ pull-up resistor to VIO

UART / Control Bus I/O Pin Characteristics (VIO = 3.3V)

<i>Parameter</i>	<i>Description</i>	<i>Min</i>	<i>Typ</i>	<i>Max</i>	<i>Units</i>	<i>Conditions</i>
Voh	Output Voltage High	2.2	2.7	3.2	V	I source = 1 mA
Vol	Output Voltage Low	0.3	0.4	0.5	V	I sink = 2 mA
Vin	Input Switching Threshold	1.0	1.2	1.5	V	* Note 1
VHys	Input Switching Hysteresis	20	25	30	mV	* Note 1

* Note 1 – Inputs have an internal 200kΩ pull-up resistor to VIO

UART / Control Bus I/O Pin Characteristics (VIO = 2.8V)

<i>Parameter</i>	<i>Description</i>	<i>Min</i>	<i>Typ</i>	<i>Max</i>	<i>Units</i>	<i>Conditions</i>
Voh	Output Voltage High	2.1	2.6	3.1	V	I source = 1 mA
Vol	Output Voltage Low	0.3	0.4	0.5	V	I sink = 2 mA
Vin	Input Switching Threshold	1.0	1.2	1.5	V	* Note 1
VHys	Input Switching Hysteresis	20	25	30	mV	* Note 1

* Note 1 – Inputs have an internal 200kΩ pull-up resistor to VIO

UART / Control Bus I/O Pin Characteristics (VIO = 5V, High Drive Level)

<i>Parameter</i>	<i>Description</i>	<i>Min</i>	<i>Typ</i>	<i>Max</i>	<i>Units</i>	<i>Conditions</i>
Voh	Output Voltage High	3.2	4.1	4.9	V	I source = 6 mA
Vol	Output Voltage Low	0.3	0.4	0.6	V	I sink = 6 mA
Vin	Input Switching Threshold	1.3	1.6	1.9	V	* Note 1
VHys	Input Switching Hysteresis	50	55	60	mV	* Note 1

* Note 1 – Inputs have an internal 200kΩ pull-up resistor to VIO

UART / Control Bus I/O Pin Characteristics (VIO = 3.3V, High Drive Level)

<i>Parameter</i>	<i>Description</i>	<i>Min</i>	<i>Typ</i>	<i>Max</i>	<i>Units</i>	<i>Conditions</i>
Voh	Output Voltage High	2.2	2.8	3.2	V	I source = 3 mA
Vol	Output Voltage Low	0.3	0.4	0.6	V	I sink = 8 mA
Vin	Input Switching Threshold	1.0	1.2	1.5	V	* Note 1
VHys	Input Switching Hysteresis	20	25	30	mV	* Note 1

* Note 1 – Inputs have an internal 200kΩ pull-up resistor to VIO

UART / Control Bus I/O Pin Characteristics (VIO = 2.8V, High Drive Level)

<i>Parameter</i>	<i>Description</i>	<i>Min</i>	<i>Typ</i>	<i>Max</i>	<i>Units</i>	<i>Conditions</i>
Voh	Output Voltage High	2.1	2.8	3.1	V	I source = 3 mA
Vol	Output Voltage Low	0.3	0.4	0.5	V	I sink = 8 mA
Vin	Input Switching Threshold	1.0	1.2	1.5	V	* Note 1
VHys	Input Switching Hysteresis	20	25	30	mV	* Note 1

* Note 1 – Inputs have an internal 200kΩ pull-up resistor to VIO

RSTI Pin Characteristics

<i>Parameter</i>	<i>Description</i>	<i>Min</i>	<i>Typ</i>	<i>Max</i>	<i>Units</i>	<i>Conditions</i>
V _{in}	Input Switching Threshold	1.3	1.6	1.9	V	
V _{Hys}	Input Switching Hysteresis	50	55	60	mV	

EEPROM RELIABILITY CHARACTERISTICS

Internal 1024 Bit EEPROM Characteristics

<i>Parameter Description</i>	<i>Value</i>	<i>Units</i>
Data Retention	15	Years
Read / Write Cycles	100,000	Cycles

INTERNAL CLOCK CHARACTERISTICS

Internal Clock Characteristics

<i>Parameter</i>	<i>Value</i>			<i>Units</i>
	<i>Min</i>	<i>Typ</i>	<i>Max</i>	
Frequency of Operation	11.98	12.00	12.02	MHz
Clock Period	83.19	83.33	83.47	ns
Duty Cycle	45	50	55	%

TECHNICAL SUPPORT AND FURTHER INFORMATION

For any questions relating to the USBMOD232R please contact us by Email, Fax or Phone.

Email: support@elexol.com

Ph: +61 755 743988

Fax: +61 755 743833

Elexol Pty Ltd
Level 2
Commerce Centre
146 Bundall Road, Bundall
Queensland 4217
Australia

Elexol Pty Ltd
PO Box 5972
GCMC
Queensland 9726
Australia

PRODUCT USE LIMITATIONS, WARRANTY & QUALITY STATEMENT

The USBMOD232R should not be used in any situation where it's failure or failure of the PC or software controlling it could cause human injury or severe damage to equipment. This device is not designed for or intended to be used in any life critical application.

The USBMOD232R is warranted to be free from manufacture defects for a period of 12 months from the date purchase.

Subjecting the device to conditions beyond the Absolute Maximum Ratings listed above will invalidate this warranty.

The USBMOD232R is a static sensitive device, anti static procedures should be used in the handling of this device.

All USBMOD232R units are extensively tested at time of manufacture to be free of defects.

Elexol is committed to providing products of the highest quality. Should you experience any product quality issues with this product please contact our quality assurance manager at the above address.

DISCLAIMER

This product and its documentation are provided as-is and no warranty is made or implied as to their suitability for any particular purpose.

Elexol Pty Ltd will not accept any claim for damages arising from the use of this product or documentation.

This document provides information on our products and all efforts are made to ensure the accuracy of the information contained within. The specifications of the product are subject to change and continual improvement.