

MH-Z14 CO2 Module

MH-Z14 NDIR Infrared gas module is a common type, small size sensor, using non-dispersive infrared (NDIR) principle to detect the existence of CO₂ in the air, with good selectivity, non-oxygen dependant, long life. Built-in temperature sensor can do temperature compensation; and it has digital output and analog voltage output. MH-Z14 NDIR Infrared gas module is applied in the HVAC, indoor air quality monitoring, industrial process, safety and protection monitoring, agricultrue and animal husbandry production process monitoring.

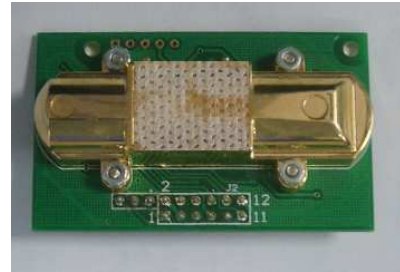

1. Technical specification:

Detection range	0~10000ppm (optional)
Resolution ratio	5ppm (0~2000ppm)
	10ppm (2000~5000ppm)
	20ppm (5000~10000ppm)
Accuracy	±50ppm±5%
Repeatability	±30ppm
Responsible time	<30S
Warm-up time	3min
Working temprature	0~50℃
Working humidity	0%~90%RH (No condensation)
Storage temprature	-20~60℃
Working voltage	4~6V
Working current	Max current <100mA, Average current <50mA
Usingage	>5year

2. Structure Dimension Chart

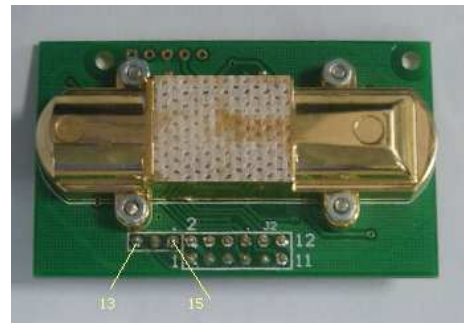
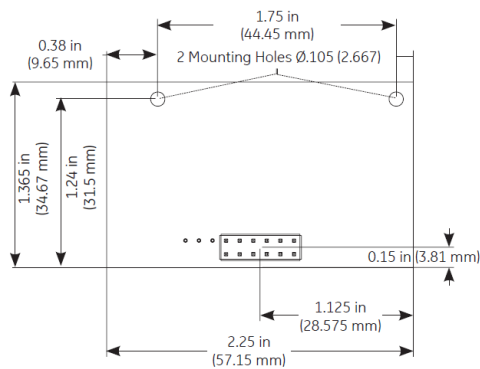

3. Signal output

Signal output: analog voltage output, PWM wave output, UART output.

Pad1、 Pad15: Vin (input voltage 4~6V)

Pad2、 Pad3、 Pad12: GND

Pad4: DAC2

Pad5: DAC1

Pad6: PWM output

Pad7、 Pad8、 Pad9: NC

Pad10、 Pad13: UART (RXD) 0~3.3V digital input

Pad11、 Pad14: UART (TXD) 0~3.3V digital output

3.1 Analog voltage output

DAC1 output voltage range (0~2.5V), corresponding gas concentration (0~full detection range)

DAC2 output voltage range (0.4~2V), corresponding gas concentration (0~full detection range)

3.2 PWM output

CO2 output range: 0ppm-2000ppm

Allowed max. current for OC: 5mA maximum

Cycle: 1004ms±5%

High level output for beginning: 2ms (in name)

Middle of cycle: 1000ms±5%

Low level output for ending: 2ms (in name)

Account formula for CO2 concentration which get through PWM:

$$C_{ppm} = 2000 \times (T_H - 2ms) / (T_H + T_L - 4ms)$$

Among:

Cppm is calculated CO2 concentration, unit is ppm;

TH is time for high level during an output cycle;

TL is time for low level during an output cycle.

3.3 Output for PWM:

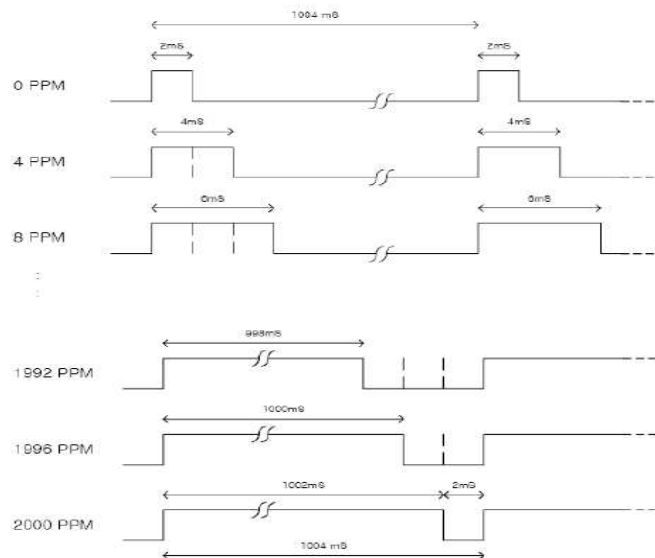

4. UART communication protocol

Data obtain procedure and hardware serial communication

Baud rate: 9600, 8 digit data, 1 digit stop bit, No parity bit

9 byte for each frame data, initially with 0xff, ending with check value

Check value= (in reverse (DATA1+DATA2+.....+DATA7)) +1

1) 1. Read concentration and temperature value of the sensor

Below order would be sent when host send concentration value of the sensor:

0	1	2	3	4	5	6	7	8
Start bit 0XFF	Detector No.	order 0x86	00	00	00	00	00	Check value

Format of data returned by subsidiary detector: :

0	1	2	3	4	5	6	7	8
Start bit 0XFF	Detector No.	High channel	Low channel	Tem. channel				Check value

Gas Concentration = High channel*256+low channel, No.of sensor: 0x01

Environment tem. value = Tem.channel

2) When make zero calibration, send value: 0xff, 0x87, 0x87, 0x00, 0x00, 0x00, 0x00, 0x00, 0xf2

The first byte (0xff) is beginning byte, the second byte (0x87) is repeated order, the third byte (0x87) is order, the last five bytes is arbitrary value, while the last byte (0xf2) is check sum. No return information.

As it is CO2 sensor, please input Nitrogen gas for 5 minutes when make zero calibration.

3) When make span calibration, send value: 0xff, 0x88, 0x88, 0x00, 0x00, 0x00, 0x00, 0x00, 0xf0

The first byte (0xff) is beginning byte, the second byte (0x88) is repeated order, the third byte (0x88) is order, the fourth byte is span perch value, the fifth byte is span low value, last 3 bytes is arbitrary value, while the last byte (0xf0) is check sum. No return information.

5. Installation

There's four installation holes

