

HF92B series

HEAT SINK

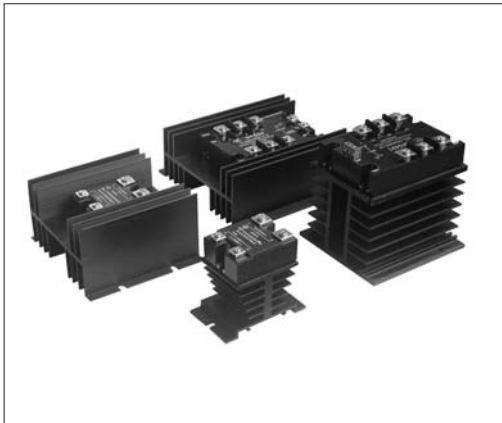

Part Number	Dimension (mm)	Thermal Resistance	Matching SSR
HF92B-80	50×50×80	2.4°C/W	HFS15: 10A,15A HFS33: 30D50M, 200D10M
HF92B-120	64×110×118	1.1°C/W	HFS15: 20A,25A HFS33: 400D10M, 150D50M, 100D20M, 50D40M, 30D100M
HF92B-150A	55×142×150	0.6°C/W	HFS15: 40A HFS24: 10A,15A, 25A HFS34: 40A, 50A HFS33: 50D80M, 100D40M, 200D40M
HF92B-150C with cooling fan	80×100×110		HFS34: 60A or more than 60A HFS24, HFS21, HFS28: 40A or more than 40A HFS33: 100A

Medium and high current SSR's dissipate heat during switching. When using an SSR this problem of heat dissipation must be managed. It is very important to select the correct heatsink to allow maximum performance from the SSR. The use of the correct heatsink has a direct influence on the maximum load current that can be switched and the maximum ambient temperature of the SSR. To assist with heat dissipation a thermal pad should be used between the relay and heatsink, or alternatively thermal conductive grease can be used. For very high performance applications, air cooling may also be necessary. Failure to manage the generation of heat by the SSR during switching may damage the SSR and lead to product failure.

We can use a simple thermal model to calculate the heat dissipation as follows:

$$T_J - T_A = P \times R_{JA}$$

In the above formula T_J stands for the junction temperature of the power parts of semiconductor (°C), T_A stands for the ambient temperature (°C), P stands for general power consumption (W) and R_{JA} stands for thermal resistance (°C/W) from junction to ambient. The thermal resistance of simplified SSR relays is made up of two parts as follow: $R_{JA} = R_{JC} + R_{CA}$. In the formula, R_{JC} stands for thermal resistance from junction to case and R_{CA} stands for the thermal resistance from case to ambient.

for example, when we calculate the heat dissipation of HFS15/D-240A25Z, R_{JC} of this relay is about 1.2°C/W, R_{CA} is about 8.5°C/W. The max. allowable junction temperature is 125°C and the power consumption is $P = U \times I$. When the current is 10A or below 10A, the TRIAC voltage drop is about 1.1V. The formula of product without heat sink is show as follow, $125 - T_A = 1.1 \times I \times (1.2 + 8.5)$.

According to the above formula, the max. current is 9.3A at 25°C ambient temperature and 6A at 60 °C ambient temperature when the product dose not add a heat sink.

If we add HF92B-120 heat sink to this relay and the reference thermal resistance is about 1.1°C/W. Neglecting the thermal resistance from SSR metal base to heat sink, and the voltage drop is about 1.25V on full load current. The formula will be $125 - T_A = 1.25 \times I \times (1.2 + 1.1)$. Max. ambient temperature will be 53°C when the operating current is 25A and the max. current will be 22A when the ambient temperature is 60°C. Due to the different heat sink types, the corresponding thermal resistance changes. So there are different current values under corresponding ambient temperature.

OUTLINE DIMENSIONS

Unit: mm

Outline Dimensions

HF92B-80

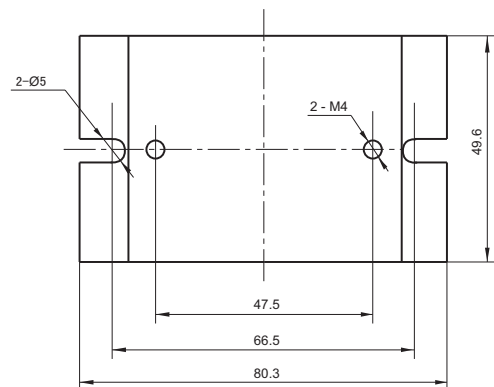
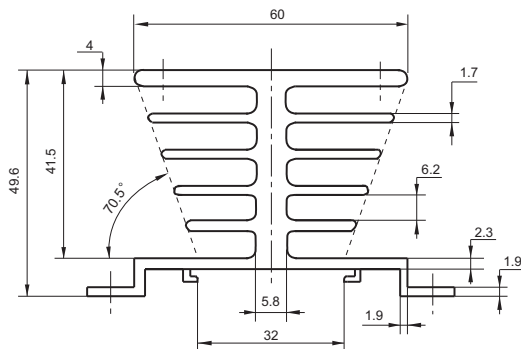

HONGFA RELAY

ISO9001, ISO/TS16949, ISO14001, OHSAS18001, IECQ QC 080000 CERTIFIED

2009 Rev. 1.00

OUTLINE DIMENSIONS

Unit: mm

Outline Dimensions

HF92B-120

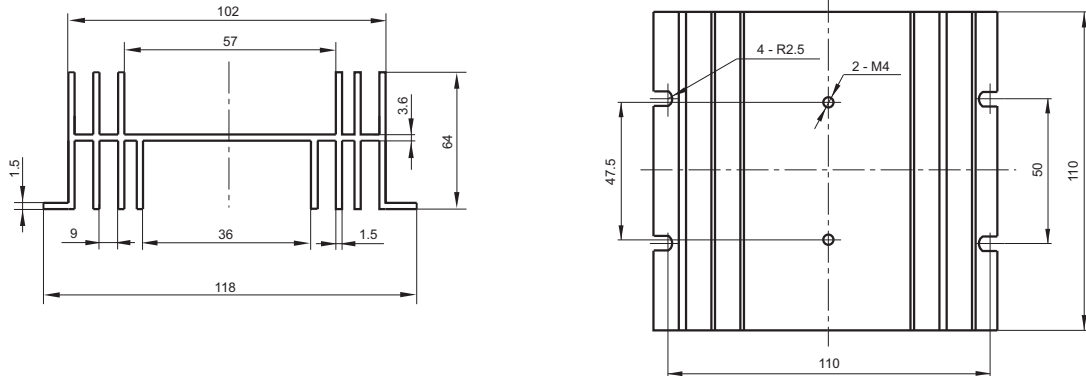

HF92B-150A

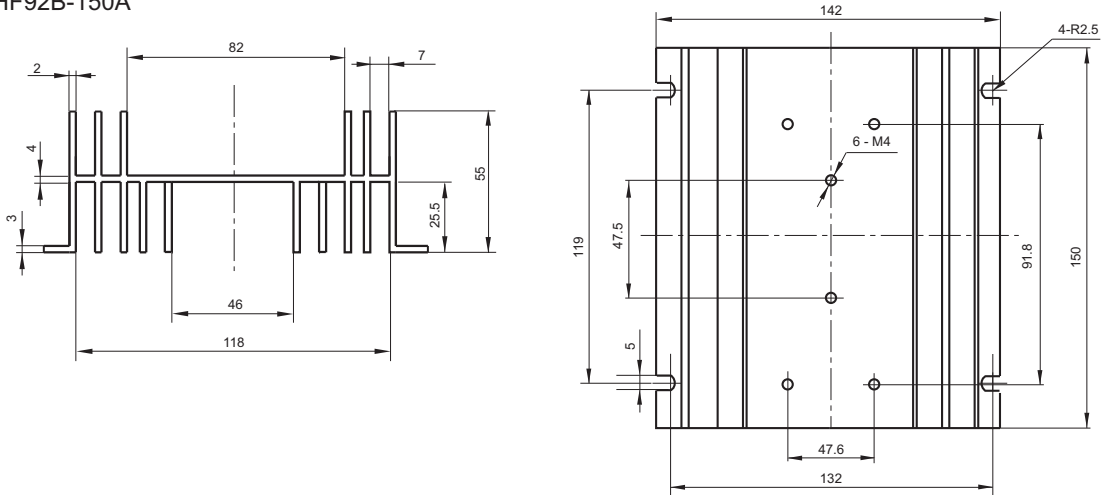

HF92B-150C

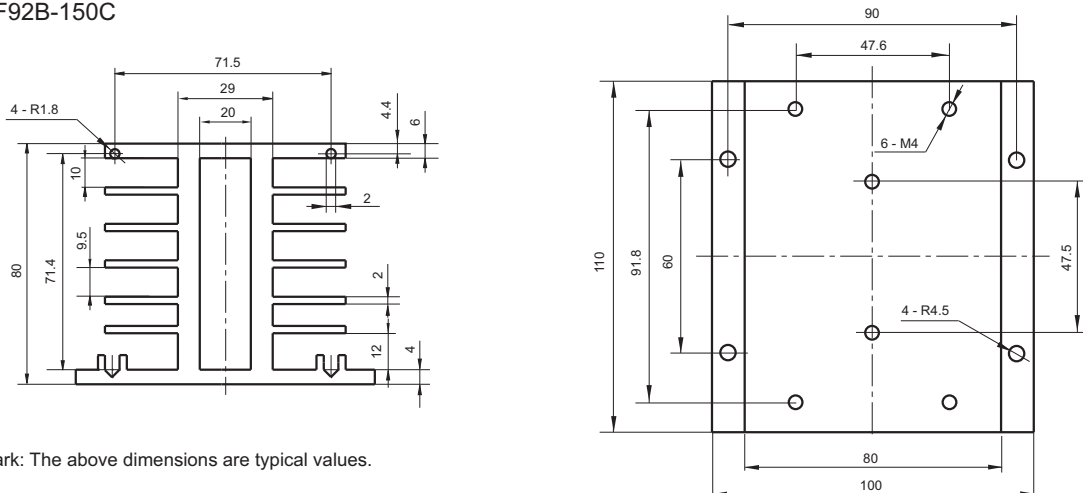

Remark: The above dimensions are typical values.

Disclaimer

This datasheet is for the customers' reference. All the specifications are subject to change without notice. We could not evaluate all the performance and all the parameters for every possible application. Thus the user should be in a right position to choose the suitable product for their own application. If there is any query, please contact Hongfa for the technical service. However, it is the user's responsibility to determine which product should be used only.