

# Fast Sensor---Flow Switch

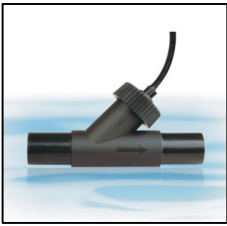

*Application:*

The switch can be widely used in petrochemical industry ,water treatment for environmental protection (Chiller, Heat pump water heater ), welding equipment ,laser equipment and some other systems for monitoring .

The switch with high performance, it equipped with permanent magnet .Just has one removable part .The Operating principle is easy .

*Features*

- No wearing and fatiguing parts applied, featuring stable performance and long service time.
- Tap water or oil applied, without using filters.;
- It could be installed horizontally and vertically ;
- Full nylon structure, various liquid corrosion resistance.
- Obstruction of the liquid is small, high efficiency .
- Max pressure is greater than 2Mpa.;

*Model Type*

FS-4P-3-22N 🇮🇸

FS-4P-5-22N 🇮🇸

FS-4P-8-22N 🇮🇸

Product Item	Lowest Flow Rate (Optional ) L/Min.			Caliber Size
FS-4P	3 🇮🇸	5 🇮🇸	8 🇮🇸	22mm (22N)

*Operation Explain*

Flow switch is mainly used in the system to instruct switch on/off according to flow rate.

To set a constant and lowest flow point in the flow switch, when the flow rate runs to the set value, switch on and the system will work, once the flow rate is less than the set value or stops, switch off.

*The picture of FS-4P-5-22N*

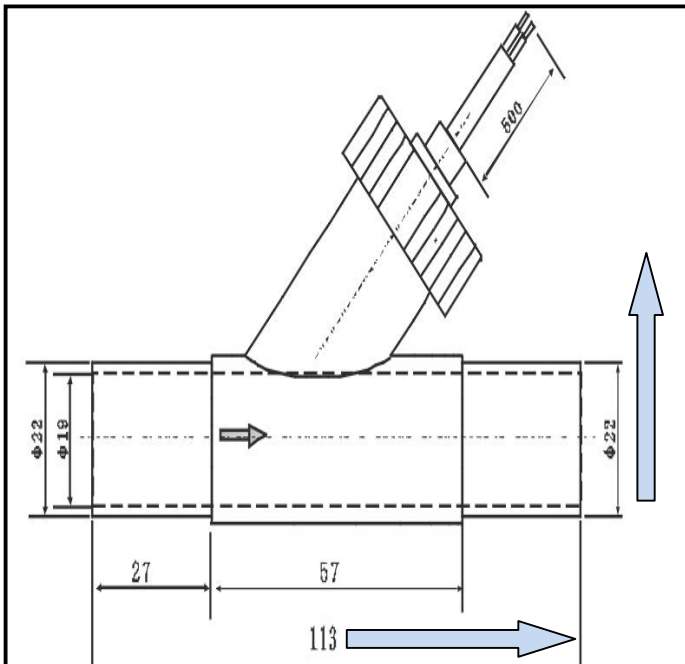

Electrical Characteristics	Units	
Material		NYLON
Ring Material		NYLON
Tempe Rating	℃	-30~+90
Max Pressure	MPa	2
Max Volume		30L
Max Contact Rating	W	70
Max Switching Voltage	VDC	≤230
Max Switching Current	A	1.0
Max contact Resistance	mOhm	200
Electrical Life (at Resistance load )	VDC/mA	1.5x10 <sup>7</sup> (20/500)
Cable Type		UL1332-AWG22
Cable Length	mm	400
Cable Color		Black

**Note :**

1. There should be no iron in the flux .
2. It is vertically and horizontally mounted and direction of water flow is upward and also towards right.

**3rd Floor of Building 8, Huaide Cuigang Industrial Park 3 Zone, Fuyong, Baoan, 518103,**

**Shenzhen, P.R China [www.szfast.com](http://www.szfast.com)**

**Tel: +86 755 2787 2991 Fax: +86 755 3393 6682 MB: +86 134 8061 4936 Email: [sophy@faster.hk](mailto:sophy@faster.hk)**