

MR513 Hot-wire type gas sensor

MR513 type alcohol sensor through alcohol absorption on the metal oxide semiconductor generates hot conduction and electronics conduction change principal, the white coil resistor change detecting gas concentration. MR513 consists detecting element and compensation element, both elements are placed in a wheatstone bridge circuit, when the alcohol concentration appears, the detecting element resistor reduces, bridge circuit voltage output changes, the voltage will increase according to the alcohol concentration increase, the compensation element refers to temperature compensation affection.

Features

- High sensitivity, large output
- Fast primary stability time, quick response
- Remarkable reproducibility and reliability.
- Goode selectivity, avoid smoke ethanol disturb
- Low consumption, miniature design

Applications

Domestic, Industrial spot alcohol concentration detection. Alcohol tester, detector and breath tester.



Configuration

Basical detecting circuit

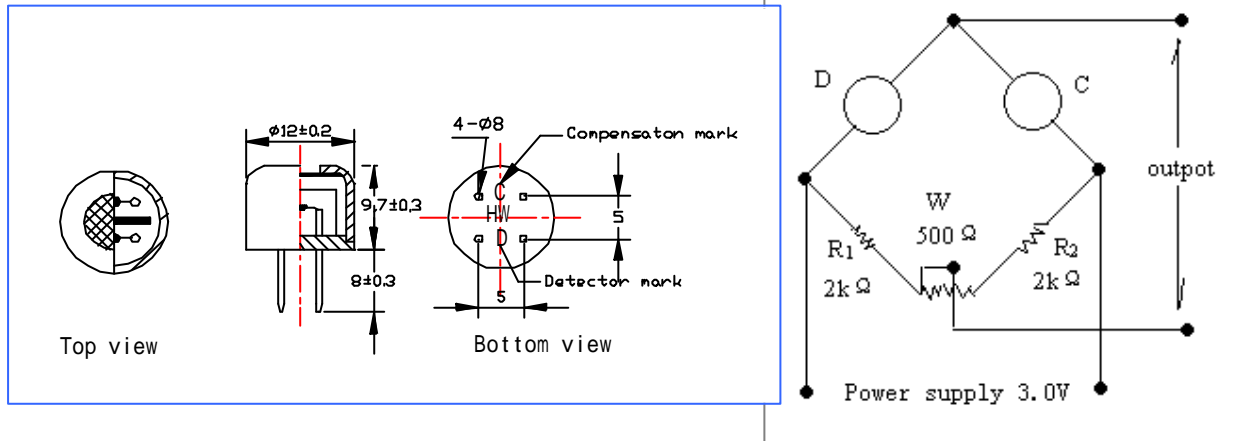

Specifications

Name		Technical parameter	
Working voltage		3.0 ± 0.1	
Working current		@100 ± 10	
sensitivity	100ppm (Ethanol)	>100	mV
Response Time (90%)		Less than 20sec	
Resume time (90%)		Less than 60sec	
Working environment		-20 - +60	Less than 95%RH
Storage environment		-30 - +80	Less than 95%RH
Size		12mmX10mm	

Sensitivity ,

Response and Resume characteristics

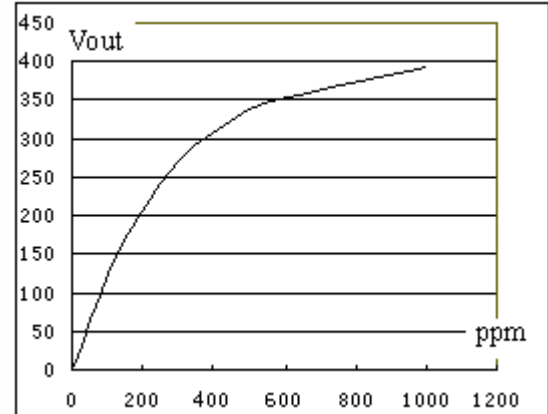
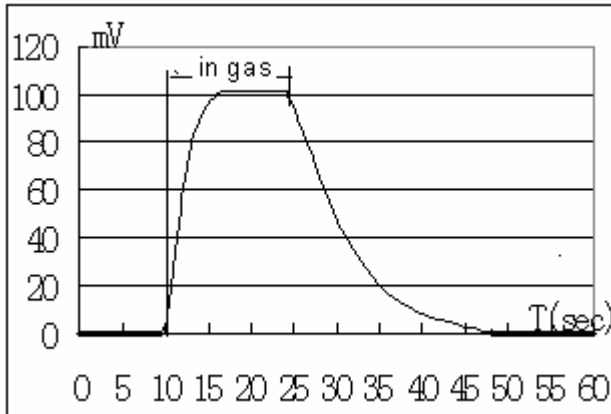

Long stability

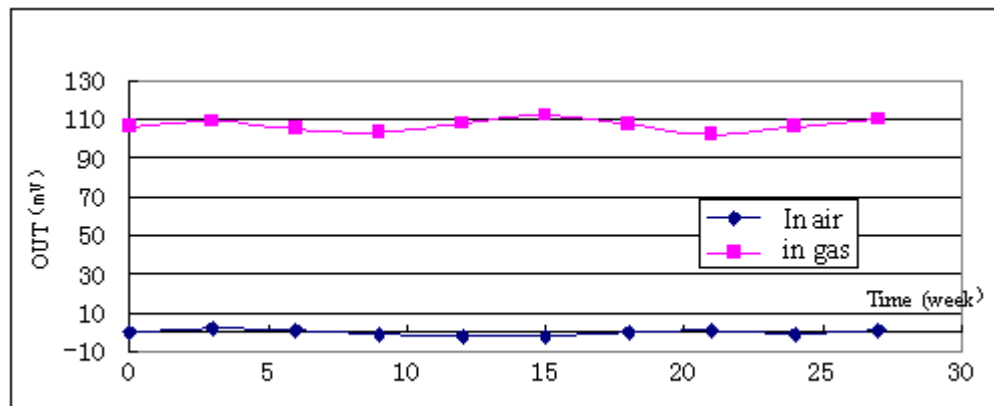

The drift in air per year will be less than 10mV, In 100ppm ethanol less than 10mV.